

MANAC HB S PILE

MANAC
HB S PILE

標準構造図

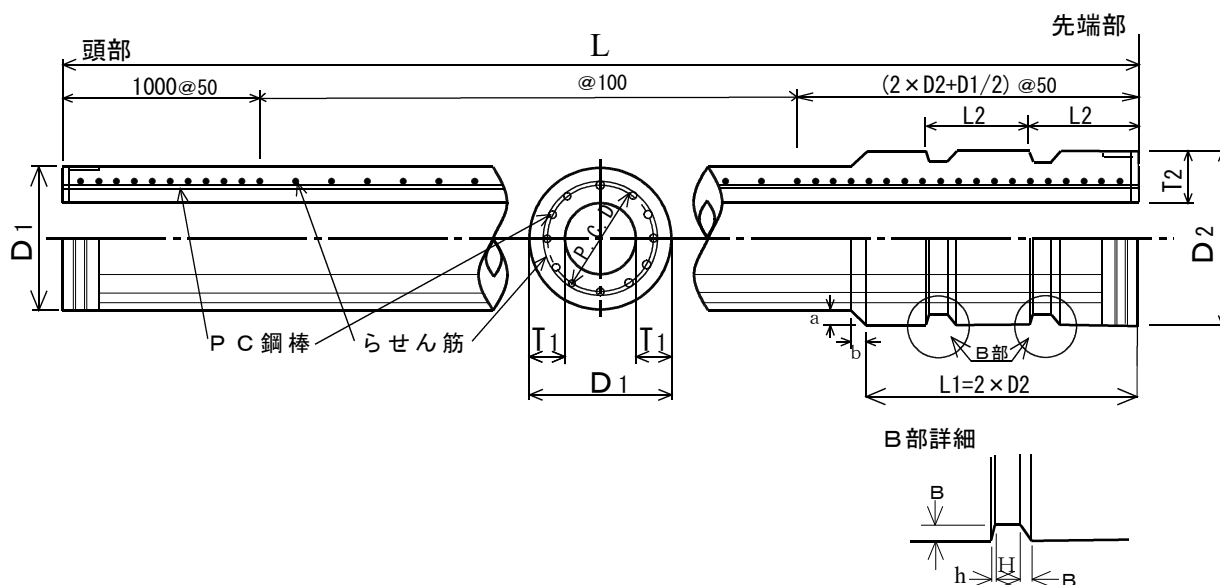

マナックHBパイプ標準規格表

呼び名	本体部 外径 D1 (mm)	拡径部 外径 D2 (mm)	種 類	厚 さ				拡径部 長 さ L1 (mm)	テーパ 部		杭長 (m)	溝 部			
				S 1		S 2			a (mm)	b (mm)		B (mm)	H (mm)	h (mm)	L2 (mm)
				T1 (mm)	T2 (mm)	T1 (mm)	T2 (mm)								
3540	350	400	A	70	95	-	-	800	25	100	5~13	20	65	4	300
			B												
			C												
4050	400	500	A	80	130	-	-	1000	50	100	5~15	25	80	5	370
			B												
			C												
4555	450	550	A	80	130	90	140	1100	50	100	5~15	25	90	5	400
			B												
			C												
5060	500	600	A	90	140	100	150	1200	50	100	5~15	30	95	6	450
			B												
			C												
6070	600	700	A	105	155	120	170	1400	50	100	5~15	30	110	6	500
			B												
			C												
7080	700	800	A	120	170	140	190	1600	50	100	5~15	35	130	7	600
			B												
			C												
8095	800	950	A	135	210	160	235	1900	75	150	5~15	45	150	9	700
			B												
			C												
80100	800	1000	A	135	235	160	260	2000	100	200	5~15	45	160	9	750
			B												
			C												
90100	900	1000	A	140	190	160	210	2000	50	100	5~15	45	160	9	750
			B												
			C												
90110	900	1100	A	140	240	160	260	2200	100	200	5~15	50	175	10	800
			B												
			C												
100120	1000	1200	A	145	245	160	260	2400	100	200	5~15	55	190	10	900
			B												
			C												

MANAC HBSPILE

MANAC
HBSPILE

本体部継手金具標準寸法表 (単位: mm)

※ S 1 ・ S 2 共通

名称	本体部 外径 D_1	拡径部 外径 D_2	種類	板厚	開先部		スカート部	
				t_1	a	b	幅 H	厚さ t_2
3540	350	400	A	12.0	8.5	3.8	100	1.6
			B	16.0				
			C	19.0				
4050	400	500	A	12.0	9.5	4.0	100	1.6
			B	19.0				
			C	22.0				
4555	450	550	A	12.0	10.0	4.2	150	1.6
			B	19.0				
			C	22.0				
5060	500	600	A	16.0	11.0	4.4	150	1.6
			B	19.0				
			C	22.0				
6070	600	700	A	16.0	12.0	4.7	150	1.6
			B	19.0				
			C	22.0				
7080	700	800	A	22.0	13.0	4.9	200	2.3
			B	22.0				
			C	25.0				
8095	800	950	A	22.0	14.0	5.2	200	2.3
			B	22.0				
			C	25.0				
80100	800	1000	A	22.0	14.0	5.2	200	2.3
			B	22.0				
			C	25.0				
90100	900	1000	A	22.0	15.0	5.5	250	3.2
			B	22.0				
			C	25.0				
90110	900	1100	A	22.0	15.0	5.5	300	3.2
			B	22.0				
			C	25.0				
100120	1000	1200	A	25.0	16.0	5.8	300	3.2
			B	28.0				
			C	28.0				

溶接金具標準構造図

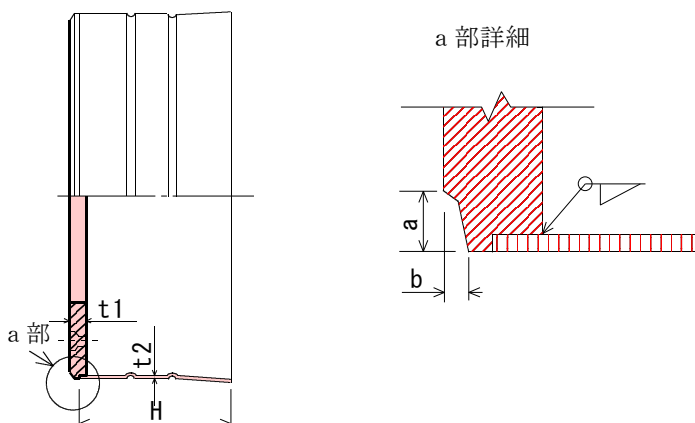

MANAC HB SPILE



許容応力度

種類	有効フレストレス (N/mm ²)	コンクリートの設計 基準強度 (N/mm ²)	長期 (N/mm ²)			短期 (N/mm ²)		
			圧縮	曲げ引張	斜め引張	圧縮	曲げ引張	斜め引張
A	4	85	24	1.0	1.2	48	2.0	1.8
B	8	85	24	2.0	1.2	48	4.0	1.8
C	10	85	24	2.5	1.2	48	5.0	1.8

設計用基礎数値

コンクリート	設計基準強度 σ_{cu}	85N/mm ²	曲げ引張強度 σ_{tu}	7.5N/mm ²	ヤング係数 E_c	4.0×10 ⁴ N/mm ²
PC鋼棒	規格	JIS G 3137 SBPDL 1275/1420				
	引張強度 σ_{pu}	1420N/mm ²	降伏点応力度 σ_{py}	1275N/mm ²	ヤング係数 E_p	2.0×10 ⁵ N/mm ²

本体部標準性能表

※白枠はS1とし、灰枠はS2とする

名称	外径 D ₁ (mm)	厚さ T ₁ (mm)	外径 D ₂ (mm)	厚さ T ₂ (mm)	長さ L (m)	断面積 A ₀ (cm ²)	種 類	P C 鋼棒			換算 断面積 A _e (cm ²)	換算断面 二次耐力 I _e ×10 ⁶ (mm ⁴)	曲げ耐力		せん断 ひび割れ Q _{cr} (kN)
								径 φ (mm)	本数 n (本)	断面積 A _p (cm ²)			曲げひび割れ M _{cr} (kN・m)	終局曲げ M _u (kN・m)	
3540	350	70	400	95	5~13	615	A S1	7.1	8	3.20	628	655	43.4	65.9	139.1
							B S1	10.0	8	6.28	641	668	58.7	114.0	173.4
							C S1	11.2	8	8.00	647	675	66.0	137.1	186.8
4050	400	80	500	130	5~15	804	A S1	7.1	10	4.00	820	1,116	64.6	95.0	181.3
							B S1	11.2	10	10.00	844	1,150	89.3	197.1	228.0
							C S1	12.6	10	12.50	854	1,164	102.0	232.6	248.1
4555	450	80	550	130	5~15	929	A S1	7.1	12	4.80	949	1,700	86.9	129.1	206.5
							B S1	11.2	12	12.00	977	1,752	120.7	269.3	260.6
							C S1	12.6	12	15.00	989	1,774	138.0	317.8	283.8
4555	450	90	550	140	5~15	1,017	A S2	7.1	12	4.80	1,037	1,786	91.2	129.4	227.9
							B S2	11.2	12	12.00	1,065	1,838	126.6	270.6	287.9
							C S2	12.6	12	15.00	1,077	1,860	144.5	320.3	313.4
5060	500	90	600	140	5~15	1,159	A S1	9.0	14	8.96	1,195	2,635	121.3	247.7	257.6
							B S1	11.2	14	14.00	1,215	2,682	166.3	356.4	325.1
							C S1	12.6	14	17.50	1,229	2,714	190.1	422.1	354.1
5060	500	100	600	150	5~15	1,256	A S2	9.0	14	8.96	1,292	2,752	127.6	248.4	283.6
							B S2	11.2	14	14.00	1,312	2,799	173.6	357.8	355.6
							C S2	12.6	14	17.50	1,326	2,831	198.2	424.5	387.2
6070	600	105	700	155	5~15	1,632	A S1	9.0	19	12.16	1,681	5,388	206.6	409.3	362.1
							B S1	11.2	19	19.00	1,708	5,481	283.3	590.2	457.0
							C S1	12.6	19	23.75	1,727	5,545	323.6	700.3	497.7
6070	600	120	700	170	5~15	1,809	A S2	9.0	19	12.16	1,857	5,699	219.6	410.7	407.4
							B S2	11.2	19	19.00	1,885	5,792	298.7	592.8	511.2
							C S2	12.6	19	23.75	1,904	5,856	335.7	703.8	550.8
7080	700	120	800	170	5~15	2,185	A S1	11.2	13	13.00	2,237	9,818	322.7	534.6	484.3
							B S1	11.2	26	26.00	2,289	10,052	445.3	937.5	611.1
							C S1	12.6	26	32.50	2,315	10,169	508.7	1111.5	665.6
7080	700	140	800	190	5~15	2,462	A S2	11.2	13	13.00	2,514	10,488	346.7	536.5	554.9
							B S2	11.2	26	26.00	2,566	10,722	475.1	942.8	697.0
							C S2	12.6	26	32.50	2,592	10,839	533.8	1120.4	750.9

MANAC HB S PILE



本体部標準性能表

※白枠はS1とし、灰枠はS2とする

名称	外径 D ₁ (mm)	厚さ T ₁ (mm)	外径 D ₂ (mm)	厚さ T ₂ (mm)	長さ L (m)	断面積 A ₀ (cm ²)	種 類	P C 鋼棒			換算 断面積 A _e (cm ²)	換算断面 二次耐力 I _e ×10 ⁶ (mm ⁴)	曲げ耐力		せん断 ひび割れ Q _{cr} (kN)
								径 φ (mm)	本数 n (本)	断面積 A _p (cm ²)			曲げひび割れ M _{cr} (kN・m)	終局曲げ M _u (kN・m)	
8095	800	135	950	210	5~15	2,819	A S1	11.2	17	17.00	2,887	16,642	478.7	801.3	624.0
							B S1	11.2	34	34.00	2,955	17,058	661.3	1406.9	787.5
							C S1	12.6	34	42.50	2,989	17,266	755.8	1668.1	857.7
8095	800	160	950	235	5~15	3,215	A S2	11.2	17	17.00	3,283	17,909	518.3	804.1	725.0
							B S2	11.2	34	34.00	3,351	18,325	710.9	1415.2	910.7
							C S2	12.6	34	42.50	3,385	18,533	799.2	1680.1	981.2
80100	800	135	1000	235	5~15	2,819	A S1	11.2	17	17.00	2,887	16,642	478.7	801.3	624.0
							B S1	11.2	34	34.00	2,955	17,058	661.3	1406.9	787.5
							C S1	12.6	34	42.50	2,989	17,266	755.8	1668.1	857.7
80100	800	160	1000	260	5~15	3,215	A S2	11.2	17	17.00	3,283	17,909	518.3	804.1	725.0
							B S2	11.2	34	34.00	3,351	18,325	710.9	1415.2	910.7
							C S2	12.6	34	42.50	3,385	18,533	799.2	1680.1	981.2
90100	900	140	1000	190	5~15	3,341	A S1	11.2	20	20.00	3,421	25,565	653.6	1071.8	736.2
							B S1	11.2	40	40.00	3,501	26,189	902.5	1892.2	929.1
							C S1	12.6	40	50.00	3,541	26,501	1031.1	2245.5	1011.8
90100	900	160	1000	210	5~15	3,718	A S2	11.2	20	20.00	3,798	27,262	696.5	1074.6	825.3
							B S2	11.2	40	40.00	3,878	27,886	963.3	1902.2	1044.0
							C S2	12.6	40	50.00	3,918	28,199	1089.2	2262.3	1129.4
90110	900	140	1100	240	5~15	3,341	A S1	11.2	20	20.00	3,421	25,565	653.6	1071.8	736.2
							B S1	11.2	40	40.00	3,501	26,189	902.5	1892.2	929.1
							C S1	12.6	40	50.00	3,541	26,501	1031.1	2245.5	1011.8
90110	900	160	1100	260	5~15	3,718	A S2	11.2	20	20.00	3,798	27,262	696.5	1074.6	825.3
							B S2	11.2	40	40.00	3,878	27,886	963.3	1902.2	1044.0
							C S2	12.6	40	50.00	3,918	28,199	1089.2	2262.3	1129.4
100120	1000	145	1200	245	5~15	3,893	A S1	11.2	24	24.00	3,989	37,525	863.5	1433.8	855.0
							B S1	11.2	48	48.00	4,085	38,454	1192.6	2533.7	1078.9
							C S1	12.6	48	60.00	4,133	38,919	1362.8	3004.7	1175.0
100120	1000	160	1200	260	5~15	4,220	A S2	11.2	24	24.00	4,316	39,502	920.7	1436.5	941.4
							B S2	11.2	48	48.00	4,412	40,431	1257.1	2545.7	1177.4
							C S2	12.6	48	60.00	4,460	40,896	1435.2	3026.3	1281.9

マナック株式会社

本社 / 〒452-0005	愛知県清須市西枇杷島町恵比須17	TEL052-501-5351	FAX052-502-4329
東京支店 / 〒164-0001	東京都中野区中野51-1-5 シティ-OTM	TEL03-5942-8528	FAX03-5942-8529
浜松支店 / 〒435-0028	静岡県浜松市中央区飯田町306	TEL053-463-4545	FAX053-463-1698
大阪支店 / 〒541-0056	大阪府大阪市中央区南船場1-12-3 ARCA心齋橋ビル8F	TEL06-6263-0760	FAX06-6263-0763
豊橋営業所 / 〒441-8052	愛知県豊橋市花田町野黒63-12	TEL0532-35-4245	FAX0532-33-4230
岐阜営業所 / 〒503-1331	岐阜県養老郡養老町橋爪新宮野575-1	TEL0584-34-1335	FAX0584-34-0124
静岡出張所 / 〒427-0008	静岡県静岡市駿河区稲川1丁目1番6号 フォレスト静岡駅前201号	TEL054-207-9251	FAX054-207-9252
浜松工場 / 〒431-3101	静岡県浜松市中央区豊町3257	TEL053-434-1073	FAX053-435-3338
養老工場 / 〒503-1331	岐阜県養老郡養老町橋爪新宮野575-1	TEL0584-34-1335	FAX0584-34-0124

