

# MANAC HB PILE

MANAC  
HB PILE

## 標準構造図

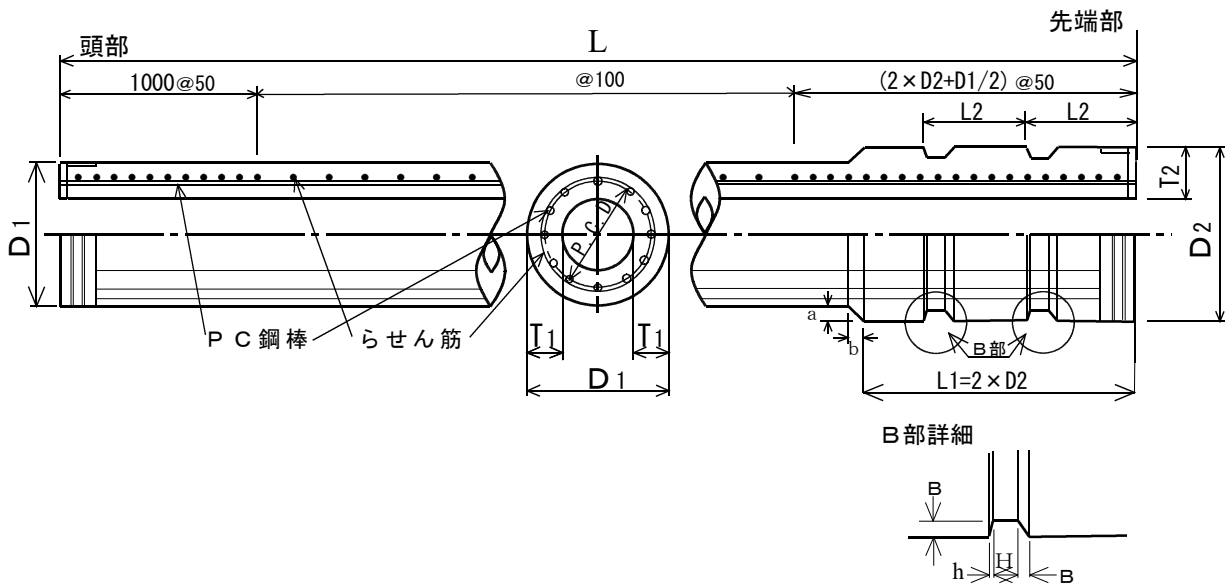

## マナックHBパイロ標準規格表

呼び名	本体部 外径 D1 (mm)	拡張部 外径 D2 (mm)	種 類	厚 さ		拡張部 長さ L1 (mm)	テーパー 部		杭長 (m)	溝 部			
				T1 (mm)	T2 (mm)		a (mm)	b (mm)		B (mm)	H (mm)	h (mm)	L2 (mm)
3035	300	350	A	60	85	700	25	100	5~13	15	55	3	250
			B										
			C										
3540	350	400	A	60	85	800	25	100	5~13	20	65	4	300
			B										
			C										
4050	400	500	A	65	115	1000	50	100	5~15	25	80	5	370
			B										
			C										
4555	450	550	A	70	120	1100	50	100	5~15	25	90	5	400
			B										
			C										
5060	500	600	A	80	130	1200	50	100	5~15	30	95	6	450
			B										
			C										
6070	600	700	A	90	140	1400	50	100	5~15	30	110	6	500
			B										
			C										
7080	700	800	A	100	150	1600	50	100	5~15	35	130	7	600
			B										
			C										
8095	800	950	A	110	185	1900	75	150	5~15	45	150	9	700
			B										
			C										
80100	800	1000	A	110	210	2000	100	200	5~15	45	160	9	750
			B										
			C										
90100	900	1000	A	120	170	2000	50	100	5~15	45	160	9	750
			B										
			C										
90110	900	1100	A	120	220	2200	100	200	5~15	50	175	10	800
			B										
			C										
100120	1000	1200	A	130	230	2400	100	200	5~15	55	190	10	900
			B										
			C										

# MANAC HB PILE



## 本体部継手金具標準寸法表 (単位: mm)

名称	本体部 外径 $D_1$	拡径部 外径 $D_2$	種類	板厚	開先部		スカート部	
				$t_1$	a	b	幅 H	厚さ $t_2$
3035	300	350	A	12.0	8.0	3.6	100	1.6
			B	16.0				
			C	19.0				
3540	350	400	A	12.0	8.5	3.8	100	1.6
			B	16.0				
			C	19.0				
4050	400	500	A	12.0	9.5	4.0	100	1.6
			B	16.0				
			C	19.0				
4555	450	550	A	12.0	10.0	4.2	150	1.6
			B	16.0				
			C	19.0				
5060	500	600	A	12.0	11.0	4.4	150	1.6
			B	16.0				
			C	19.0				
6070	600	700	A	14.0	12.0	4.7	150	1.6
			B	16.0				
			C	19.0				
7080	700	800	A	19.0	13.0	4.9	200	2.3
			B	19.0				
			C	22.0				
8095	800	950	A	19.0	14.0	5.2	200	2.3
			B	19.0				
			C	22.0				
80100	800	1000	A	19.0	14.0	5.2	200	2.3
			B	19.0				
			C	22.0				
90100	900	1000	A	19.0	15.0	5.5	250	3.2
			B	19.0				
			C	22.0				
90110	900	1100	A	19.0	15.0	5.5	300	3.2
			B	19.0				
			C	22.0				
100120	1000	1200	A	19.0	16.0	5.8	300	3.2
			B	19.0				
			C	22.0				

## 溶接金具標準構造図

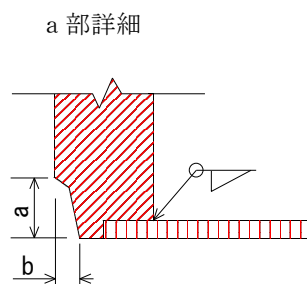
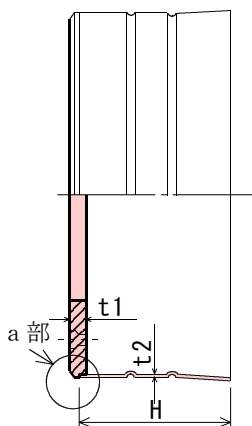

# MANAC HB PILE



## 許容応力度

種類	有効フレストレス (N/mm <sup>2</sup> )	コンクリートの設計 基準強度 (N/mm <sup>2</sup> )	長期 (N/mm <sup>2</sup> )			短期 (N/mm <sup>2</sup> )		
			圧縮	曲げ引張	斜め引張	圧縮	曲げ引張	斜め引張
A	4	85	24	1.0	1.2	48	2.0	1.8
B	8	85	24	2.0	1.2	48	4.0	1.8
C	10	85	24	2.5	1.2	48	5.0	1.8

## 設計用基礎数値

コンクリート	設計基準強度 $\sigma_{cu}$	85N/mm <sup>2</sup>	曲げ引張強度 $\sigma_{tu}$	7.5N/mm <sup>2</sup>	ヤング係数 $E_c$	$4.0 \times 10^4$ N/mm <sup>2</sup>
PC鋼棒	規格	JIS G 3137 SBPDL 1275/1420				
	引張強度 $\sigma_{pu}$	1420N/mm <sup>2</sup>	降伏点応力度 $\sigma_{py}$	1275N/mm <sup>2</sup>	ヤング係数 $E_p$	$2.0 \times 10^5$ N/mm <sup>2</sup>

## 本体部標準性能表

名称 (mm)	外径 $D_1$ (mm)	厚さ $T_1$ (mm)	外径 $D_2$ (mm)	厚さ $T_2$ (mm)	長さ $L$ (m)	断面積 $A_0$ (cm <sup>2</sup> )	種 類	P C 鋼棒			換算 断面積 $A_e$ (cm <sup>2</sup> )	換算断面 二次耐力 $I_e$ ×10 <sup>6</sup> (mm <sup>4</sup> )	曲げ耐力		せん断 ひび割れ $Q_{cr}$ (kN)
								径 $\phi$ (mm)	本数 $n$ (本)	断面積 $A_p$ (cm <sup>2</sup> )			曲げひび割れ $M_{cr}$ (kN・m)	終局曲げ $M_u$ (kN・m)	
3035	300	60	350	85	5~13	452	A	7.1	6	2.40	462	353	24.5	37.3	99.1
							B	10.0	6	4.71	471	360	34.3	61.8	126
							C	11.2	6	6.00	476	364	39.2	78.5	136
3540	350	60	400	85	5~13	546	A	7.1	8	3.20	559	613	34.3	52.0	119
							B	10.0	8	6.28	571	626	49.0	88.3	150
							C	11.2	8	8.00	578	633	58.9	117.7	163
4050	400	65	500	115	5~15	684	A	7.1	10	4.00	700	1,018	54.0	81.4	148
							B	10.0	10	7.85	715	1,040	73.6	132.4	187
							C	11.2	10	10.00	724	1,052	88.3	176.6	204
4555	450	70	550	120	5~15	835	A	7.1	12	4.80	854	1,594	73.6	110.8	181
							B	10.0	12	9.42	873	1,627	107.9	194.2	228
							C	11.2	12	12.00	883	1,646	122.6	245.2	248
5060	500	80	600	130	5~15	1,055	A	7.1	14	5.60	1,077	2,463	103.0	155.0	229
							B	10.0	14	10.99	1,099	2,513	147.2	264.9	288
							C	11.2	14	14.00	1,111	2,541	166.8	333.5	314
6070	600	90	700	140	5~15	1,441	A	7.1	19	7.60	1,472	4,935	166.8	250.2	311
							B	10.0	19	14.92	1,501	5,034	245.2	441.4	392
							C	11.2	19	19.00	1,517	5,089	284.5	569.0	428
7080	700	100	800	150	5~15	1,884	A	10.0	13	10.21	1,925	8,898	264.9	397.3	406
							B	10.0	26	20.41	1,966	9,081	372.8	671.0	512
							C	11.2	26	26.00	1,988	9,182	441.4	882.9	557
8095	800	110	950	185	5~15	2,383	A	10.0	17	13.35	2,437	14,871	392.4	588.6	512
							B	10.0	34	26.69	2,490	15,198	539.6	971.2	647
							C	11.2	34	34.00	2,519	15,377	637.6	1275.0	704
80 100	800	110	1000	210	5~15	2,383	A	10.0	17	13.35	2,437	14,871	392.4	588.6	512
							B	10.0	34	26.69	2,490	15,198	539.6	971.2	647
							C	11.2	34	34.00	2,519	15,377	637.6	1275.0	704
90 100	900	120	1000	170	5~15	2,939	A	10.0	20	15.70	3,002	23,371	539.6	809.3	631
							B	10.0	40	31.40	3,065	23,861	735.8	1324.0	797
							C	11.2	40	40.00	3,099	24,129	833.8	1668.0	867
90 110	900	120	1100	220	5~15	2,939	A	10.0	20	15.70	3,002	23,371	539.6	809.3	631
							B	10.0	40	31.40	3,065	23,861	735.8	1324.0	797
							C	11.2	40	40.00	3,099	24,129	833.8	1668.0	867
100 120	1000	130	1200	230	5~15	3,551	A	10.0	24	18.84	3,627	35,080	735.8	1104.0	762
							B	10.0	48	37.68	3,702	35,810	1030.0	1854.0	961
							C	11.2	48	48.00	3,743	36,209	1177.0	2354.0	1047

## マナック株式会社

本社 / 〒452-0005 愛知県清須市西枇杷島町恵比須17  
 浜松支店 / 〒435-0028 静岡県浜松市南区飯田町306  
 大阪支店 / 〒541-0056 大阪府大阪市中央区南船場1-12-3 (船場グランドビル)  
 東京営業所 / 〒164-0001 東京都中野区中野51-1-5 ティー・エム・ティ  
 豊橋営業所 / 〒441-8052 愛知県豊橋市花田町野黒63-12  
 岐阜営業所 / 〒501-1152 岐阜県岐阜市又丸20-1  
 滋賀営業所 / 〒522-0074 滋賀県大津市大將軍3-10-12 初代ビル103号  
 静岡出張所 / 〒427-0008 静岡県静岡市駿河区聖一色157-1 サブ・ラ・B2  
 浜松工場 / 〒431-3101 静岡県浜松市東区豊町3257  
 養老工場 / 〒503-1331 岐阜県養老郡養老町橋爪新宮野575-1

TEL052-501-5351 FAX052-502-4329  
 TEL053-463-4545 FAX053-463-1698  
 TEL06-6263-0760 FAX06-6263-0763  
 TEL03-5942-8528 FAX03-5942-8529  
 TEL0532-35-4245 FAX0532-33-4230  
 TEL058-230-0018 FAX058-230-0018  
 TEL0775-48-6180 FAX0775-48-6181  
 TEL054-207-9251 FAX054-207-9252  
 TEL053-434-1073 FAX053-435-3338  
 TEL0584-34-1335 FAX0584-34-0124