

マナックNAC（PHC）パイル
標準仕様書

1. 杭体の種類・寸法・構造



図 - 1 マナックNACパイル標準構造図

表 - 1 マナックNACパイルの種類及び寸法

杭径 D (mm)	種類	厚さ T		杭長 (m)	杭径 D (mm)	種類	厚さ T		杭長 (m)
		Nタイプ (mm)	Sタイプ (mm)				Nタイプ (mm)	Sタイプ (mm)	
300	A	60	-	5~13	600	A	90	120	5~15
	B			5~15					
	C								
350	A	60	70	5~13	700	A	100	140	5~15
	B			5~15					
	C								
400	A	65	80	5~15	800	A	110	160	5~15
	B								
	C								
450	A	70	90	5~15	900	A	120	160	5~15
	B								
	C								
500	A	80	100	5~15	1000	A	130	160	5~15
	B								
	C								

表 - 2 コンクリートの許容応力度

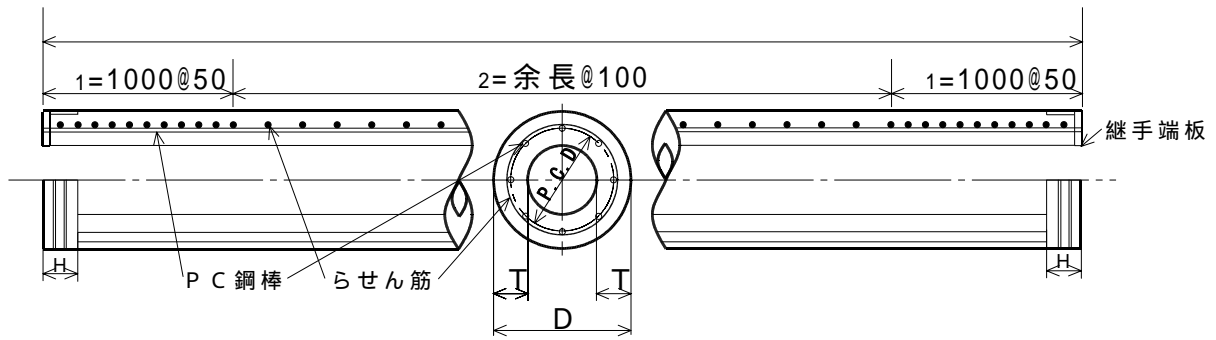
種類	コンクリートの設計 基準強度(N/mm ²)	長期 (N/mm ²)			短期 (N/mm ²)		
		圧縮	曲げ引張	斜め引張	圧縮	曲げ引張	斜め引張
A	85	24	1.0	1.2	48	2.0	1.8
B	85	24	2.0	1.2	48	4.0	1.8
C	85	24	2.5	1.2	48	5.0	1.8

Nタイプ 表 - 3 マナックNACパイロ標準性能表

杭径 (本体部) D (mm)	種類	厚さ T (mm)	長さ (m)	断面積 A _o (mm ²)	P C 鋼棒				有効 プ レ ス テ ス t r e s s e (N/mm ²)	コンクリート 断面積 A _c × 10 ² (mm ²)	換算 断面積 A _e × 10 ² (mm ²)	換算断面 二次モーメント I _e × 10 ⁶ (mm ⁴)	換算断面 係 数 Z _e × 10 ³ (mm ³)	設計曲げモーメント		設計せん断力	
					公称径 (mm)	本数 (本)	配筋直径 P.C.D (mm)	断面積 A _p (cm ²)						ひび割れ M _{cr} (kN・m)	破壊 Mu (kN・m)	短期 Q _{as} (kN)	耐力 Q (kN)
300	A	60	5 ~ 13	45239	7.1	6	240	2.40	4.0	450	462	353	2353	27.2	42.0	76.3	101.7
	B		5 ~ 15		10.0	6		4.71	8.0	448	471	360	2398	37.2	72.4	98.9	128.0
	C		11.2		6	6.00		9.7	446	476	363	2422	41.7	87.2	107.2	137.9	
350	A	60	5 ~ 13	54664	7.1	8	290	3.20	4.0	543	559	613	3501	40.3	65.6	90.8	121.1
	B		5 ~ 15		10.0	8		6.28	8.0	540	572	626	3575	55.5	113.4	118.1	152.9
	C		11.2		8	8.00		10.0	539	579	633	3617	63.4	136.3	129.7	166.6	
400	A	65	5 ~ 15	68408	7.1	10	335	4.00	4.0	680	700	1018	5091	58.5	94.5	113.2	151.0
	B		10.0		10	7.85		8.0	676	715	1040	5199	80.6	163.8	147.3	190.6	
	C		11.2		10	10.00		10.0	674	724	1052	5259	92.2	197.1	161.7	207.8	
450	A	70	5 ~ 15	83566	7.1	12	380	4.80	4.0	831	855	1594	7085	81.7	128.7	138.4	184.5
	B		10.0		12	9.42		8.0	826	873	1628	7234	112.0	224.2	179.3	232.1	
	C		11.2		12	12.00		10.0	824	884	1646	7316	128.1	270.0	196.9	253.0	
500	A	80	5 ~ 15	105557	7.1	14	430	5.60	4.0	1050	1078	2464	9855	113.2	168.8	174.5	232.7
	B		10.0		14	10.99		8.0	1045	1100	2514	10054	155.8	296.3	226.9	293.8	
	C		11.2		14	14.00		9.8	1042	1112	2541	10166	175.6	357.9	246.6	317.1	
600	A	90	5 ~ 15	144199	7.1	19	520	7.60	4.0	1434	1472	4937	16457	189.5	277.0	238.0	317.3
	B		10.0		19	14.915		8.0	1427	1502	5036	16786	259.4	489.1	308.3	399.2	
	C		11.2		19	19.00		9.7	1423	1518	5091	16971	292.2	591.1	335.1	430.9	
700	A	100	5 ~ 15	188496	10.0	13	600	10.205	4.0	1875	1926	8902	25433	292.9	434.0	310.6	414.1
	B		10.0		26	20.41		8.0	1865	1967	9085	25958	402.2	776.1	403.0	521.7	
	C		11.2		26	26.00		10.0	1859	1989	9186	26245	460.1	936.8	442.9	569.0	
800	A	110	5 ~ 15	238447	10.0	17	700	13.345	4.0	2371	2438	14878	37195	429.2	649.4	393.0	523.8
	B		10.0		34	26.69		8.0	2358	2491	15205	38013	590.3	1162.5	509.9	660.1	
	C		11.2		34	34.00		10.0	2350	2520	15384	38461	671.3	1402.4	557.6	716.5	
900	A	120	5 ~ 15	294053	10.0	20	790	15.70	4.0	2925	3003	23382	51960	595.7	867.5	481.0	641.7
	B		10.0		40	31.40		8.0	2909	3066	23872	53049	821.7	1564.5	626.9	811.6	
	C		11.2		40	40.00		10.0	2901	3101	24140	53645	936.9	1890.7	687.2	883.0	
1000	A	130	5 ~ 15	355314	10.0	24	880	18.84	4.0	3534	3629	35097	70194	809.7	1160.4	584.3	778.8
	B		10.0		48	37.68		8.0	3515	3704	35827	71653	1113.0	2098.4	758.4	981.7	
	C		11.2		48	48.00		9.9	3505	3745	36226	72453	1261.5	2536.6	827.8	1063.8	

Sタイプ 表 - 4 マナックNACパイプ標準性能表

杭径 (本体部) D (mm)	種類	厚さ T (mm)	長さ (m)	断面積 A _o (mm ²)	P C 鋼棒				有効 プレスト レスト ce (N/mm ²)	コンクリート 断面積 A _c × 10 ² (mm ²)	換算 断面積 A _e × 10 ² (mm ²)	換算断面 二次モーメント I _e × 10 ⁶ (mm ⁴)	換算断面 係 数 Z _e × 10 ³ (mm ³)	設計曲げモーメント		設計せん断力		
					公称径 (mm)	本数 (本)	配筋直径 P.C.D (mm)	断面積 A _p (cm ²)						ひび割れ M _{cr} (kN・m)	破壊 Mu (kN・m)	短期 Q _{as} (kN)	耐力 Q (kN)	
300	A	60	5~13	45239	7.1	6	240	2.40	4.1	450	462	353	2353	27.3	42.0	76.6	102.1	
	B		5~15		10.0	6		4.71	8.0	448	471	360	2398	37.2	72.4	98.9	128.0	
	C		11.2		6	6.00		9.8	446	476	363	2422	41.8	87.2	107.4	138.1		
350	A	70	5~13	61575	7.1	8	290	3.20	4.1	613	629	655	3741	43.4	65.9	104.4	139.1	
	B		5~15		10.0	8		6.28	7.9	609	641	668	3815	58.7	114.0	133.9	173.4	
	C				11.2	8		8.00	9.6	608	648	675	3856	66.0	137.1	145.2	186.8	
400	A	80	5~15	80425	7.1	10	335	4.00	4.1	800	820	1116	5581	64.6	95.0	136.1	181.3	
	B					11.2		10	10.00	8.0	794	844	1150	5749	89.3	197.1	176.1	228.0
	C					12.6		10	12.50	10.0	792	854	1164	5820	102.0	232.6	193.1	248.1
450	A	90	5~15	101788	7.1	12	380	4.80	4.0	1013	1037	1787	7941	91.2	129.4	170.9	227.9	
	B					11.2		12	12.00	8.0	1006	1066	1839	8172	126.6	270.6	222.4	287.9
	C					12.6		12	15.00	10.0	1003	1078	1860	8268	144.5	320.3	243.9	313.4
500	A	100	5~15	125664	9.0	14	430	8.96	4.1	1248	1292	2753	11013	127.6	248.4	212.9	283.6	
	B					11.2		14	14.00	8.0	1243	1313	2800	11199	173.6	357.8	274.7	355.6
	C					12.6		14	17.50	10.0	1239	1327	2832	11329	198.2	424.5	301.3	387.2
600	A	120	5~15	180956	9.0	19	520	12.16	4.1	1797	1858	5702	19005	219.6	410.7	305.7	407.4	
	B					11.2		19	19.00	8.0	1791	1886	5794	19314	298.7	592.8	394.8	511.2
	C					12.6		19	23.75	9.7	1786	1905	5858	19528	335.7	703.8	428.3	550.8
700	A	140	5~15	246301	11.2	13	600	13.00	4.1	2450	2515	10492	29978	346.7	536.5	416.5	554.9	
	B					11.2		26	26.00	8.0	2437	2567	10726	30647	475.1	942.8	538.4	697.0
	C					12.6		26	32.50	9.7	2431	2593	10843	30981	533.8	1120.4	584.0	750.9
800	A	160	5~15	321699	11.2	17	700	17.00	4.1	3200	3285	17917	44792	518.3	804.1	544.2	725.0	
	B					11.2		34	34.00	8.0	3183	3353	18333	45834	710.9	1415.2	703.5	910.7
	C					12.6		34	42.50	9.7	3174	3387	18542	46354	799.2	1680.1	763.0	981.2
900	A	160	5~15	371964	11.2	20	790	20.00	4.0	3700	3800	27275	60612	696.5	1074.6	618.9	825.3	
	B					11.2		40	40.00	8.0	3680	3880	27899	61999	963.3	1902.2	806.6	1044.0
	C					12.6		40	50.00	9.9	3670	3920	28212	62692	1089.2	2262.3	878.7	1129.4
1000	A	160	5~15	422230	11.2	24	880	24.00	4.1	4198	4318	39521	79042	920.7	1436.5	707.3	941.4	
	B					11.2		48	48.00	8.0	4174	4414	40450	80901	1257.1	2545.7	909.7	1177.4
	C					12.6		48	60.00	10.0	4162	4462	40915	81830	1435.2	3026.3	997.9	1281.9